

Designing Linear Circuits for 5V Single Supply Operation

Jim Williams

In predominantly digital systems it is often necessary to include linear circuit functions. Traditionally, separate power supplies have been used to run the linear components (see Box, "Linear Power Supplies—Past, Present, and Future").

Recently, there has been increasing interest in powering linear circuits directly from the 5V logic rail. The logic rail is a difficult place for analog components to function. The high amplitude broadband current and voltage noise generated by logic clocking makes analog circuit operation difficult. (See Box, "Using Logic Supplies for Linear Functions".)

Generally speaking, analog circuitry which must achieve very high performance levels should be driven from dedicated supplies. The difficulties encountered in maintaining the lowest possible levels of noise and drift in an analog system are challenging enough without contending with a digitally corrupted power supply.

Many analog applications, however, can be successfully implemented using the logic supply. Combining components intended to provide high performance from the log-

ic rail with good design can give excellent results (see Box, "High Performance, Single Supply Analog Building Blocks"). The examples which follow show this in a variety of precision measurement and control circuits which function from a 5V supply.

Linearized RTD Signal Conditioner

Figure 1 shows a circuit which provides complete, linearized signal conditioning for a platinum RTD. One side of the RTD sensor is grounded, often desirable for noise considerations. The Q1-Q2 current source is referenced to A1's output. A1's operating point is primarily fixed by the 2.5V LT1009 voltage reference. The RTD's constant current forces the voltage across it to vary with its resistance, which has a nearly linear positive temperature coefficient. The non-linearity causes several degrees of error over the circuit's 0°C-400°C operating range. A2 amplifies R_p 's output, while simultaneously supplying non-linearity correction. The correction is implemented by feeding a portion of A2's output back to A1's input via the 10k-250k divider. This causes the Q1-Q2 current source

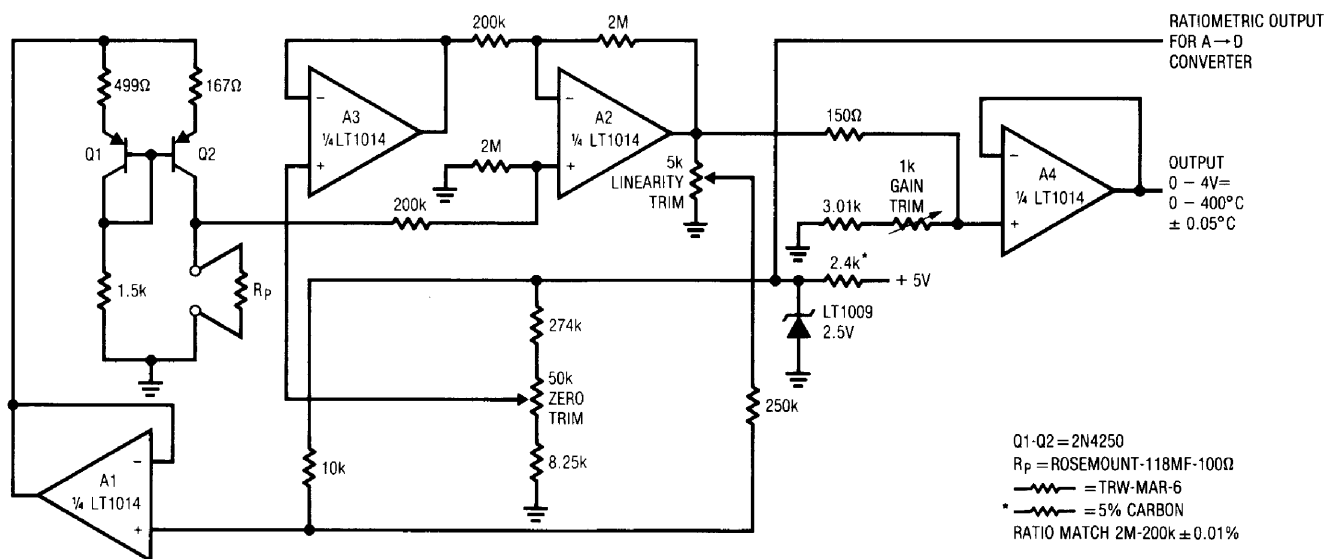

Figure 1. Linearized Platinum RTD Signal Conditioner

Application Note 11

output to shift with R_p 's operating point, compensating sensor non-linearity to within $\pm 0.05^\circ\text{C}$. A3, also referenced to the LT1004, voltage sums an offsetting signal at A2's negative input, allowing 0°C to equal 0V at A2's output. The resistive divider in A4's input line sets circuit gain, and the circuit's output is taken at A4.

To calibrate this circuit, substitute a precision decade box (e.g., General Radio 1432K) for R_p . Set the box to 0°C value (100.00Ω) and adjust the zero trim for a 0.0V output. Next, set the decade box for a 140°C output (154.26Ω) and adjust the gain trim for a 1.400V output reading. Finally, set the box to 400°C (249.00Ω) and trim the linearity adjustment for a 4.000V output. Repeat this sequence until all three points are fixed. Total error over the entire range will be within $\pm 0.05^\circ\text{C}$. The resistance values given are for a nominal 100.00Ω (0°C) sensor. Sensors deviating from this nominal value can be used by factoring in the deviation from 100.00Ω . This deviation, which is manufacturer-specified for each individual sensor, is an offset term due to winding tolerances during fabrication of the RTD. The gain slope of the platinum is primarily fixed by the purity of the material and is a very small error term.

Linearized Output Methane Detector

Figure 2 is another 5V-powered transducer circuit. Like the platinum RTD example, this circuit linearizes the transducer's output, but it performs a more complex mathematical operation. The circuit's frequency output is directly proportional to the methane concentration detected by the transducer specified. Figure 3 shows that the transducers output varies as;

$$\approx \frac{1}{\sqrt{\text{Concentration}}}$$

The circuit linearizes this function and its frequency output is also plotted.

The sensor's resistance vs methane concentration is converted to a voltage by A1. The LT1034 serves as a reference. A1's output feeds A2. The exponential relationship between V_{BE} and collector current in transistors is

utilized to generate a current in Q3's collector proportional to the square of A2's input current. This operation compensates the sensor's square root term. Q3's collector current sets the operating point of the A3-A4 oscillator. A3, an integrator, generates a positive going linear ramp (Trace A, Figure 4). The ramp is compared with Q3's current at A4's summing point (Trace B). A4 is configured as a current summing comparator. The feedback diode-bound network minimizes delay due to output slew time. When the ramp forces the summing point positive, A4's output (Trace C) swings negative. CMOS inverter A (Trace D) goes high, turning on the CD4016 switch to reset the A3 integrator. Simultaneously, inverter B goes low (Trace E), supplying AC positive feedback to A4's "+" input (Trace F). When the positive feedback decays, A4's output goes high, A3 begins to integrate, and the entire cycle repeats. Q3's collector current determines how long A3's ramp runs before A4 resets it. The ramp time is directly proportional to Q3's collector current, meaning that oscillation frequency is inversely (1/X) related to the current. The overall circuit transfer function is;

$$\frac{1}{X^2}$$

This linearizes the sensor's output. In practice, the sensor's response slightly deviates from the equation shown, actually being;

$$\frac{1}{\sqrt[1.9]{\text{Concentration}}}$$

The reset time constants at A4's input introduce enough oscillator "dead time" to partially compensate for the deviation. The dead time's frequency retarding characteristic effects the oscillator's high frequency range, providing a first order correction. The overall linearization achieved is within the sensor's manufacturing tolerances. The slight "bump" in the circuit's response curve is due to the mismatch between the sensors term and the circuits X^2 function.

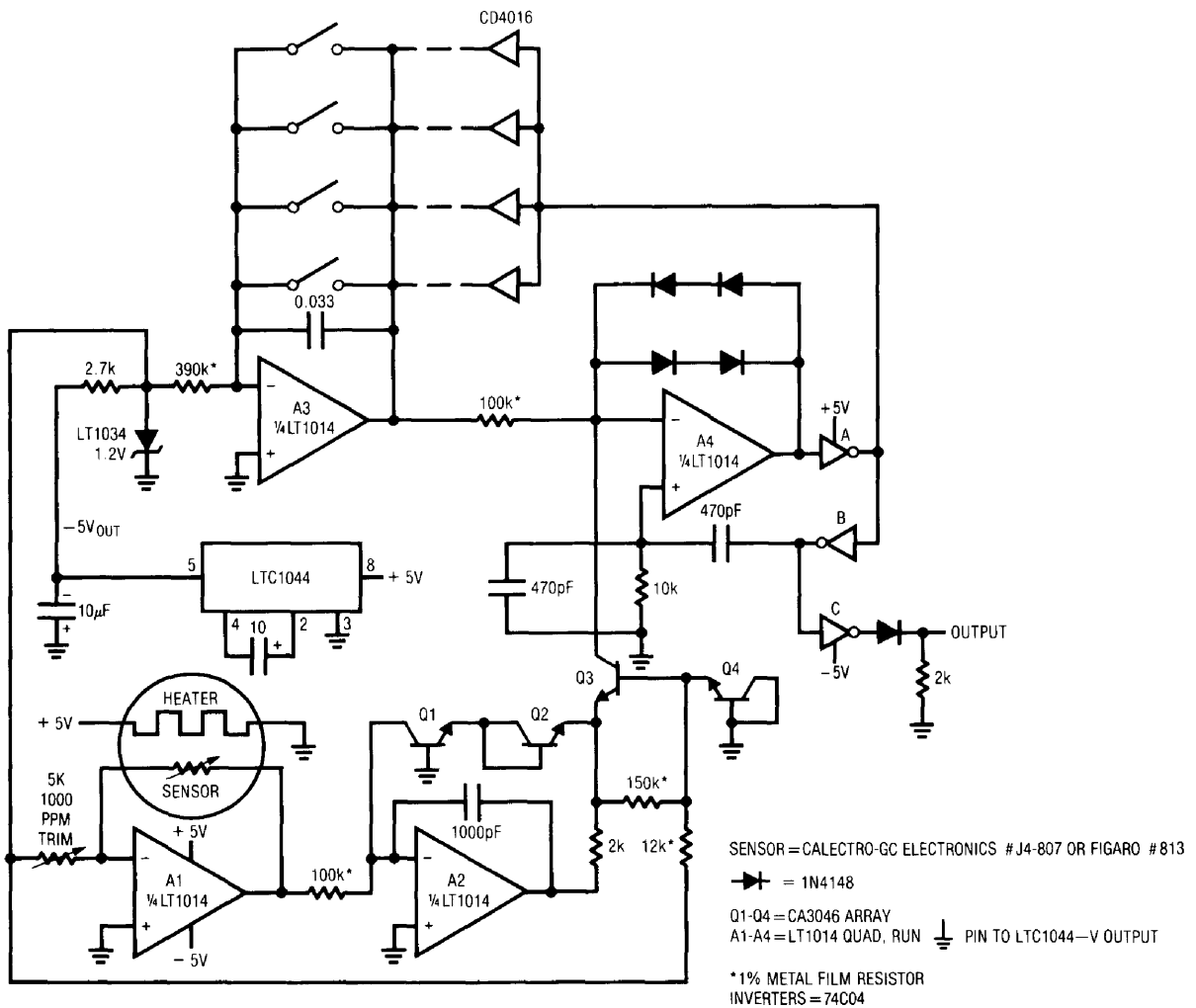

Figure 2. Linearized Methane Transducer Signal Conditioner

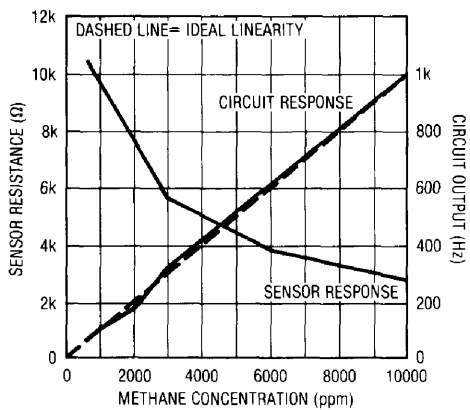

Figure 3. Transducer vs Circuit Response

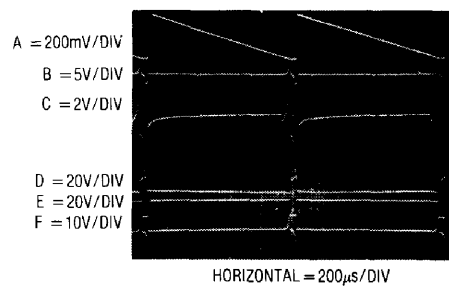

Figure 4. Linearized Methane Detector Waveforms

The dead time correction in the oscillator smoothes this error out above 4000ppm. The LTC1044 voltage converter generates a negative supply directly from the 5V rail. This approach provides necessary negative circuit potentials while maintaining compatibility with 5V-supply-only operation. The sensor's heater is powered directly from the 5V rail, as specified by the manufacturer. To calibrate the circuit, place the sensor in a 1000ppm methane environment and adjust the 5k trim for a 100Hz output. Accuracy from 500ppm to 10,000ppm is limited by the sensor's 10% specification.

Cold Junction Compensated Thermocouple Signal Conditioner

Figure 5 shows a 5V powered, complete thermocouple signal conditioner. Cold junction compensation is included, and the circuit allows one leg of the thermocouple to be grounded, desirable for noise considerations. The LTC1043 combines the cold junction network differential output with the grounded thermocouple's signal at the LTC1052. The LTC1052 provides stable, low drift gain. To enable swing all the way to ground, the LTC1043's other switch section generates a small negative potential. This allows the LTC1052 output stage to run Class A for small outputs, permitting swing to 0V. The table gives proper values for R_1 for various thermocouples. Output scaling may be set by R_f/R_i to whatever slope is desirable. Cold junction compensation holds within $\pm 1^\circ\text{C}$ over 0°C – 60°C .

5V Powered Precision Instrumentation Amplifier

Many transducer outputs require a true differential input "instrumentation" type amplifier. Transducers with single ended outputs do not, in theory, require a differential input amplifier but common-mode noise often exceeds the signal of interest. For these reasons, transducer systems often employ these type amplifiers.

No commercially manufactured instrumentation amplifier will function from a 5V supply and achieving good precision in a design is difficult. The circuits in Figure 6 meet these requirements. They also feature input protection, filtering capability and a shield driving output.

In Figure 6A, A1, A2 and A3 accomplish the differential-input-to-single-ended-output conversion, with R_g setting gain. The LT1014's high open loop gain permits accurate circuit gain. Offset and drift performance allows use with low level transducers such as thermocouples and strain gauges. The $100\text{k}\Omega$ - $1\mu\text{F}$ combination filters noise and 60Hz pickup; the amplifier is never exposed to high frequency common-mode noise. The transistor-diode clamps combine with the $100\text{k}\Omega$ resistors to prevent high voltage spikes or faults (common in industrial environments) from damaging the amplifiers. A4 is used as a shield driver to reduce the effects of input cable capacitance. It drives the shield at the input common-mode voltage, which is derived from the input amplifier's output. Performance characteristics are summarized in the table.

Figure 6B achieves greater DC precision at the expense of bandwidth. Here, the LTC1043 switched capacitor building block alternately commutates a $1\mu\text{F}$ capacitor between the circuit input and the LTC1052's input. This stage, accomplishing a differential-to-single-end transition, allows the chopper stabilized LTC1052 to take a ground referred measurement. The LTC1043's other switch stage generates a small negative potential, allowing the LTC1052 output to swing all the way to 0V. DC precision is excellent, surpassing all monolithic $\pm 15\text{V}$ instrumentation amps, although bandwidth is limited to 10Hz. The LTC1043's switching action, set at about 400Hz by the $0.01\mu\text{F}$ value, forms a low pass filter. This permits extremely high rejection of noise, allowing the CMRR to remain above 120dB at 20kHz. Overall performance is summarized in the table.

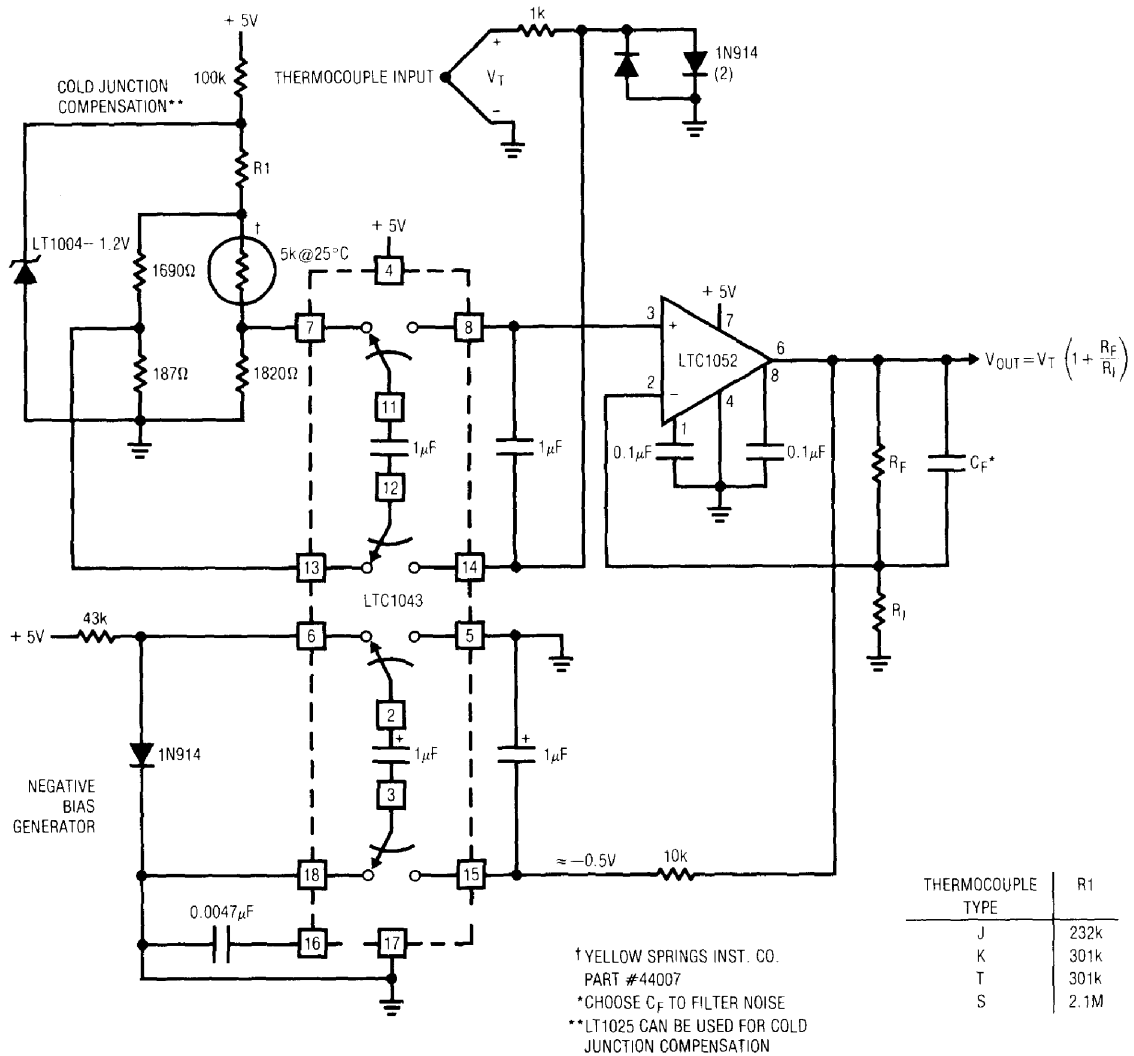

Figure 5. Cold Junction Compensated Thermocouple Signal Conditioner

Application Note 11

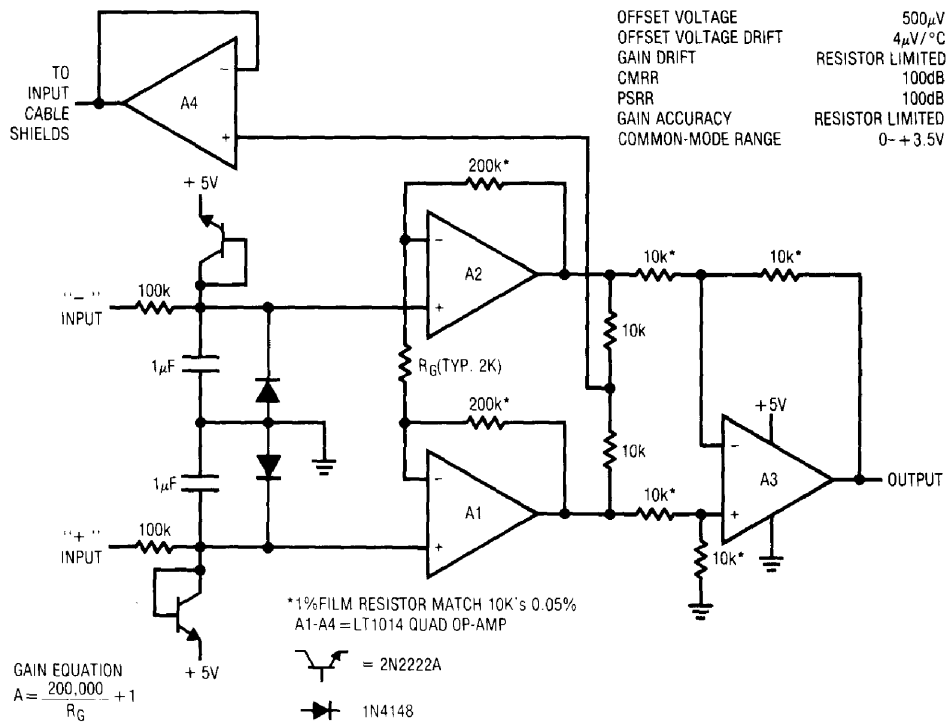

Figure 6A. Precision Instrumentation Amplifier

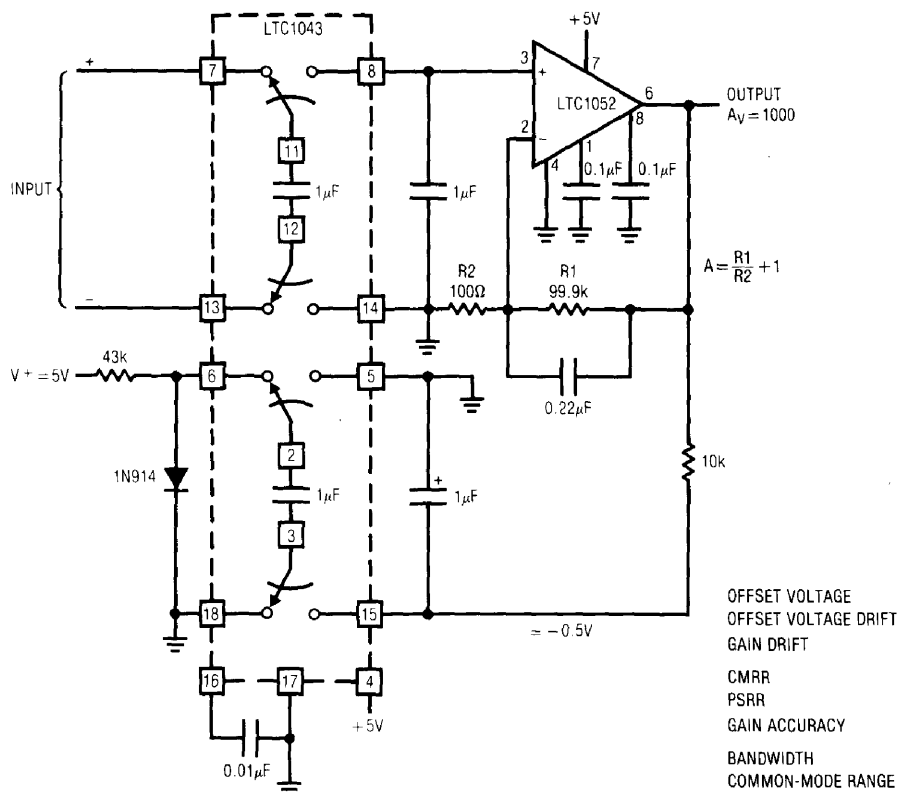

Figure 6B. Ultra Precision Instrumentation Amplifier

5V Powered Strain Gauge Signal Conditioner

Figure 7 shows an unusual approach to signal conditioning the bridge output of a strain gauge pressure transducer. The 5V circuit needs only two amplifiers and provides an auxiliary ratio output for a monitoring A-D converter. The design functions by converting the bridge's differential output into a ground referred single ended signal which is then amplified. This approach eliminates common-mode errors by eliminating the bridge's common-mode output component. Additionally, the number of precision resistors required is minimized and no matching is required.

A1 biases the LTC1044 positive-to-negative converter. The LTC1044's output pulls the bridge's output negative, causing A1's input to balance at 0V. This local loop permits a single-ended amplifier (A2) to extract the bridge's output signal. The 100k-0.33μF RC filter's noise and A2's gain is set to provide the desired output scale factor. Because bridge drive is derived from the LT1034 reference, A2's output is not affected by supply shifts. The LT1034's output is

available for ratio operation. To calibrate this circuit, apply or electrically simulate 0psi and trim the zero adjustment for 0V output. Next, apply or electrically simulate 350psi and trim gain for 3.500V out. Repeat these adjustments until both points are fixed.

"Tachless" Motor Speed Controller

Figure 8 shows a way to servo control the speed of a DC motor. This circuit is particularly applicable to digitally controlled systems in robotic and X-Y positioning applications. By functioning from the 5V logic supply it eliminates additional motor drive supplies. The "tachless" feedback saves additional space and cost. The circuit senses the motor's back EMF to determine its speed. The difference between the speed and a setpoint is used to close a sampled loop around the motor. Because no commercially available sample-hold circuit will run from a 5V supply, special techniques are required.

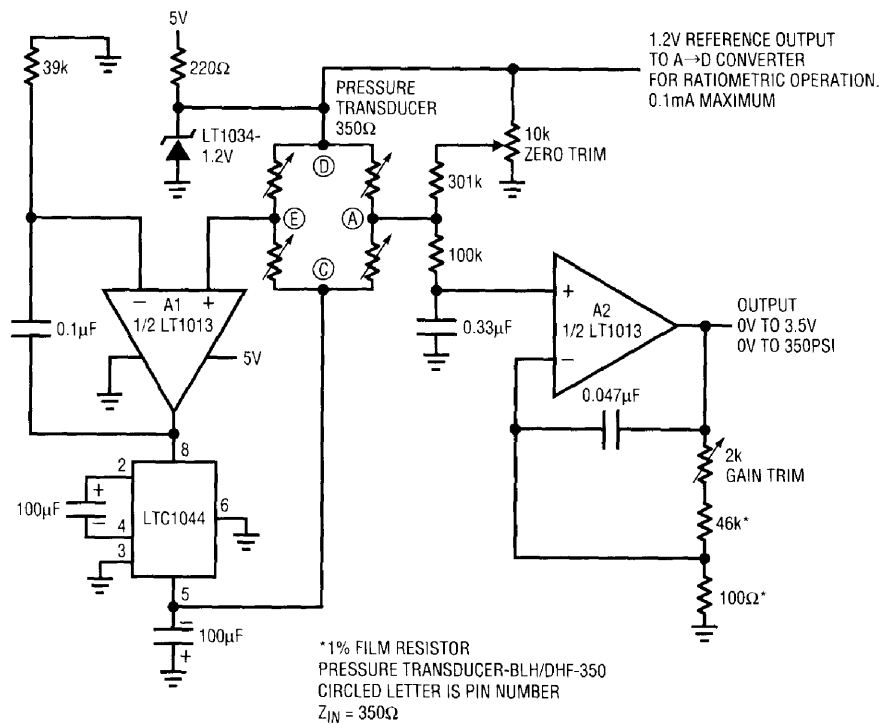

Figure 7. Strain Gauge Signal Conditioner

Application Note 11

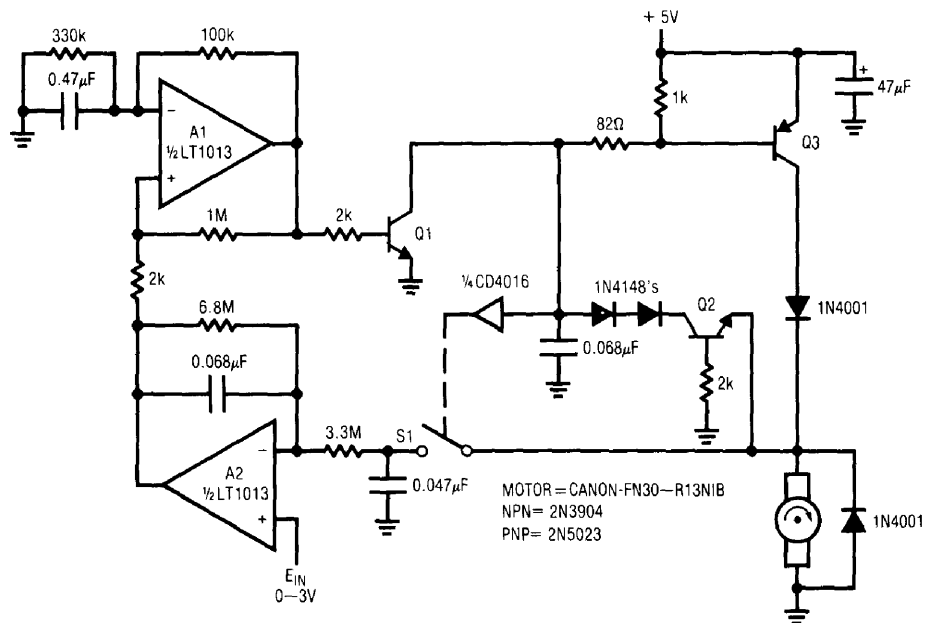

Figure 8. "Tachless" Motor Speed Controller

A1 generates a pulse train (Trace A, Figure 9). When A1's output is high, Q1 is biased and Q3 drives the motor's ungrounded terminal (Trace B). When A1 goes low, Q3 turns off and the motor's back EMF appears after the inductive flyback ceases. During this period, S1's input (Trace C) is turned on, and the 0.047 capacitor acquires the back EMF's value. A2 compares this value with the setpoint and the amplified difference (Trace D) changes A1's duty cycle, controlling motor speed. A2 has the desirable characteristic of assuming unity gain in the absence of a feedback signal. Start-up or input overdrive cannot force servo lock-up due to loss of sampling action. The loop is self-restoring and will establish control when abnormal conditions cease.

Drive to S1's control input must be carefully controlled for proper operation. Q2 prevents the switch from closing until the negative going flyback interval is over and the 0.068µF capacitor slows the switches turn-on edge. These measures ensure clean back EMF acquisition in the 0.047µF unit. Q2's collector line diodes compensate the motor's clamp diode drop, preventing destructive negative voltages at S1. The circuit controls from 20rpm to full speed with good transient response under all shaft loads. The gain and roll-off terms in A2's feedback loop are optimal for the motor listed, and should be reestablished for other types.

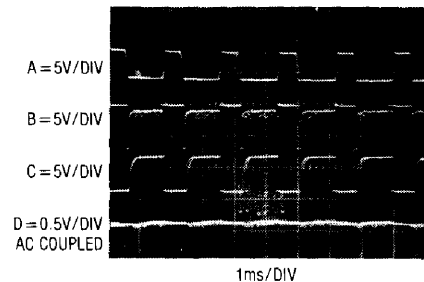

Figure 9. Motor Speed Controller Waveforms

4-20mA Current Loop Transmitter

Transmission of industry standard 4-20mA current loop signals to valves and other actuators is a common requirement. Resistive line losses and actuator impedances require current transmitters to be able to force a compliance voltage of at least 20V. Because of this, 5V powered systems usually cannot meet current loop transmitter requirements, but Figure 10 shows a way to do this. This 5V powered circuit utilizes a servo controlled DC-DC converter to generate the compliance voltage necessary for loop current requirements. It will drive 4-20mA into loads as high as 2200Ω (44V compliance) and is inherently short circuit protected. The circuit's input is applied to A2, whose output biases A1's "+" input via the offsetting network. A1's output goes high, biasing Q4 to turn on Q3. Q3's collector drives the T1-Q1-Q2 DC-DC converter, which is clocked by the RC-gate oscillator. T1 furnishes voltage

step-up and the rectified and filtered secondary current flows through the 100Ω resistor and the load. A1's negative input measures the voltage across the 100Ω resistor, completing a current control loop around T1. The 0.33μF capacitor furnishes stable loop roll-off and the 100pF unit suppresses local oscillation at Q4. Within the compliance limit, A1 maintains constant output current, regardless of load impedance shifts or supply changes. To calibrate this circuit, short the output, apply 0V to the input and adjust the "4mA trim" for 0.3996V across the 100Ω resistor. Next, shift the input to 4.000V and trim the 20mA adjustment for 1.998V across the 100Ω resistor. Repeat this procedure until both points are fixed. The gain trim network shunting the 100Ω resistor necessitates the odd voltage trim target values, but output current swings between 4.000mA and 20.00mA.

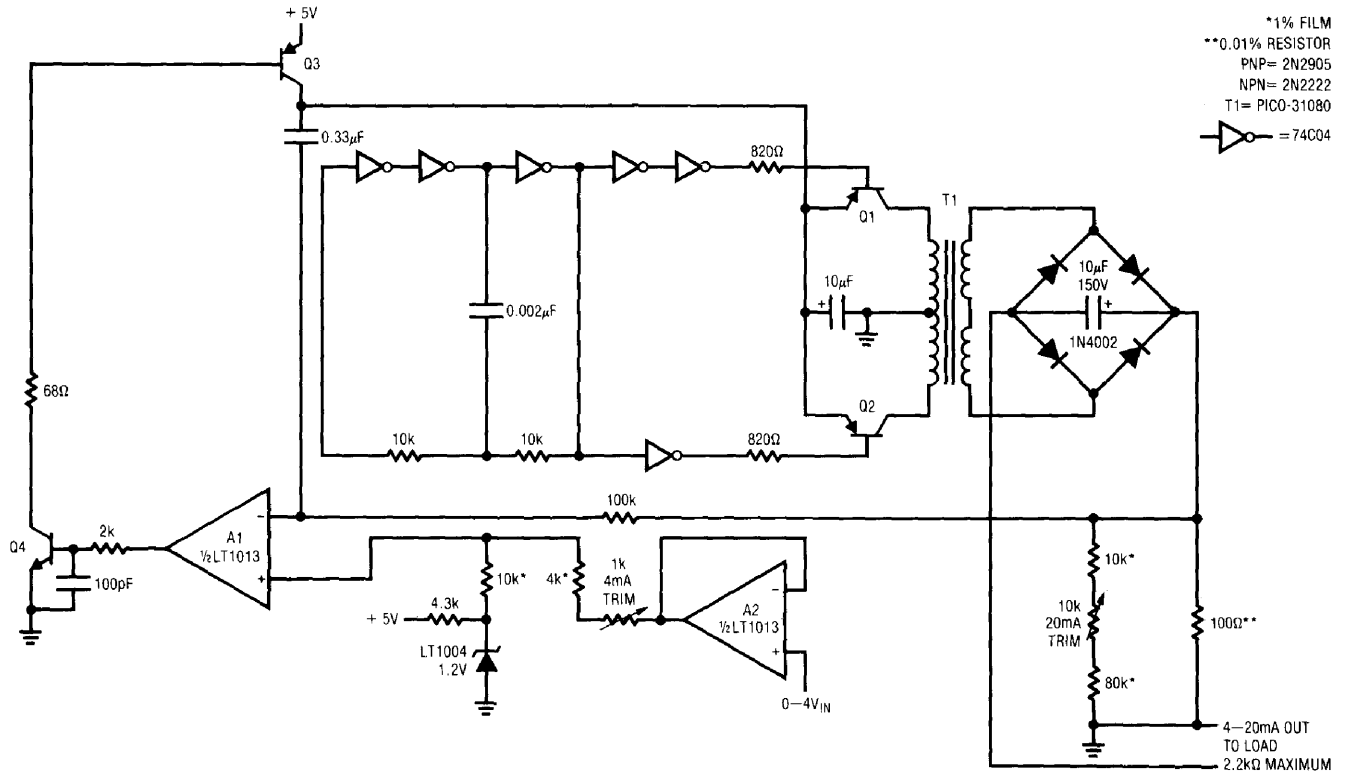

Figure 10. 4-20mA Current Loop Transmitter

Application Note 11

Figure 11 details modifications which permit the circuit's output current to galvanically float. This is often useful in industrial situations where the output lines may be exposed to common-mode voltages or high voltage fault conditions. The transformer's primary current, which theoretically reflects current delivered by the secondary, is sensed across a shunt and fed back via A2. In practice,

current control precision is limited by non-ideal transformer behavior to about 1%. Common-mode voltage is limited by T1's 300V breakdown.

Fully Isolated Limit Comparator

Figure 12's 5V powered circuit performs a fully isolated limit comparison on low level signals. It produces a digital

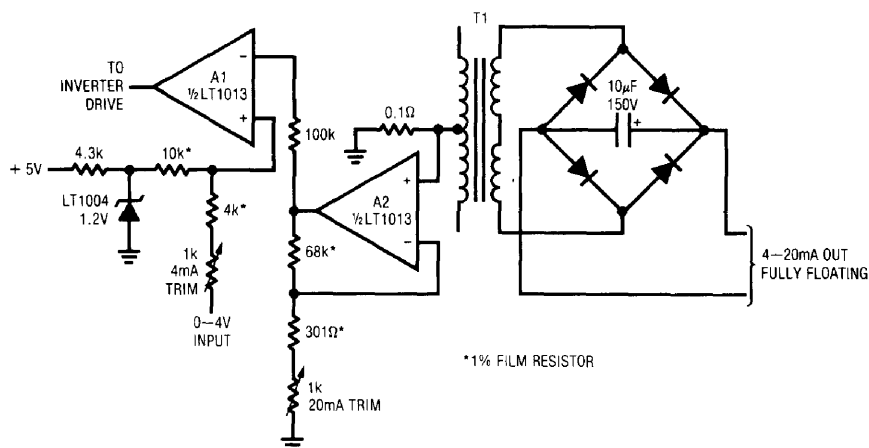

Figure 11. Floating Output Option for Current Loop Transmitter

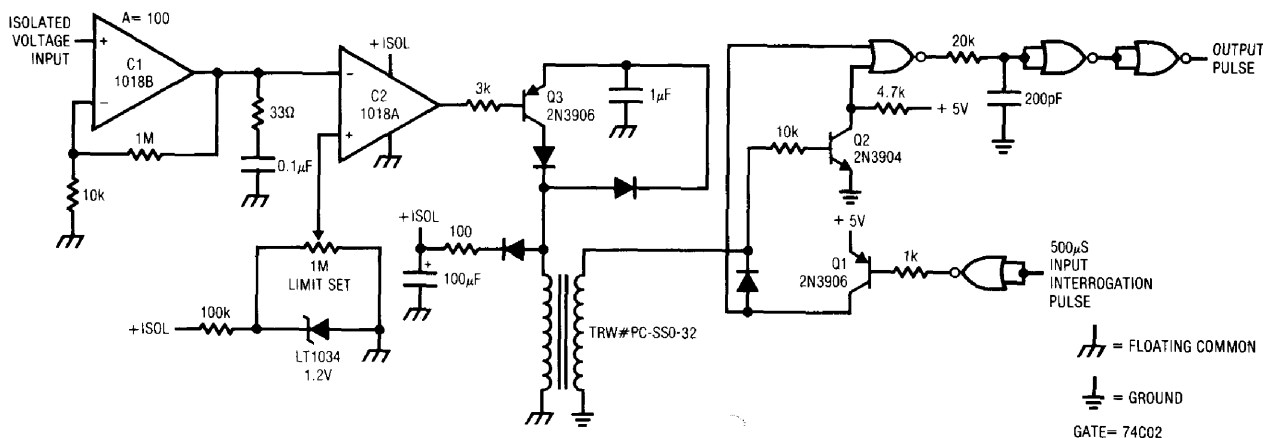

Figure 12. Fully Isolated Limit Comparator with Gain of 100.

output indicating if the input is above or below a preset limit. This circuit is ideal for process control applications where transducers operate at high common-mode voltages or where large ground loops exist. An uncommitted gain-of-100 amplifier allows thermocouples and other low level sources to be used with the circuit. The circuit functions by echoing an interrogation pulse if the input is above a preset level. If the input is below this level, no echo pulse occurs. A transformer is used to allow a two-way, galvanically isolated signal path and the energy contained in the interrogation pulse powers the circuit's floating elements. Figure 13 shows operating waveforms for the "above limit" case. When an input interrogation pulse is applied, Q1's collector drives the transformer primary (Figure 13, Trace A). Energy is transferred to the transformer's secondary and stored in the 100 μ F capacitor. The charge in the capacitor powers the isolated circuitry (" + ISOL" potential indicated in Figure 12). If low

power dual comparator C2's output is low, Q3 biases and drives current into the transformer secondary (Trace B). This is reflected in the transformer's primary (Trace C). Q2 and the associated gate circuitry form a demodulator which produces an output pulse (Trace D). If C2's output had been high (below limit set), the transformer would have received no secondary drive and there would be no output pulse. The demodulator is designed so that nothing appears on the output line unless the circuit is above the preset limit.

Comparator C1's output damper network allows it to function as an op amp for low level signals. This circuit easily extracts millivolt signals buried in high common-mode voltage or ground noise and delivers its limit decision to the output. The maximum common-mode voltage is limited by the transformer's 500V breakdown.

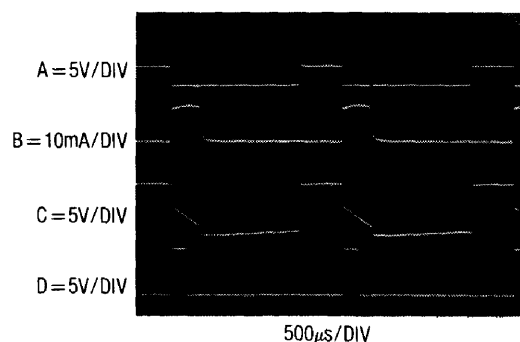

Figure 13. Isolated Limit Comparator Waveforms

Circuit operation is initiated by applying a pulse to the “convert command” input (Trace A, Figure 15). This pulse appears at the transformer secondary and charges the 100 μ F capacitor. This potential is used to supply power to the floating A–D conversion circuitry. The transformer’s secondary pulse biases the inverter-open drain buffer combination to discharge the 4 μ F capacitor (Trace B). The secondary pulse also biases a diode to stop the C1B 3kHz oscillator output (Trace D). Concurrently, C1A goes high, forcing the inverter in its output line low (Trace C). When the convert command pulse ceases, the Q1-Q2 current source charges the 4 μ F capacitor with a linear ramp. The C1B oscillator now runs. When the ramp crosses the input voltage’s value, C1A’s output switches and its output line inverter (Trace C) goes high, cutting off the oscillator. The number of oscillator pulses occurring during this interval

is proportional to the input voltage value. These pulses are differentiated and fed to Q3, which drives the transformer. The differentiation causes narrow spikes to be fed to the transformer, easing power drain on the 100 μ F energy storage capacitor. Q3’s RC base delay and the inverter-buffer combination at C1B’s output prevent Q3’s emitter pulses from triggering a ramp reset. The waveforms appearing at the transformer’s input do not reflect the circuit’s complex operation, and easily interface to a digital system. Figure 16, Trace A shows the “convert command” pulse. Trace B is the transformer primary. The differentiated oscillator pulses coming from the transformer secondary appear as small amplitude spikes. In this case, a small voltage is being converted and the number of pulses is small. Trace C, the “data output”, is taken at Q4’s collector, and the pulses are TTL compatible.

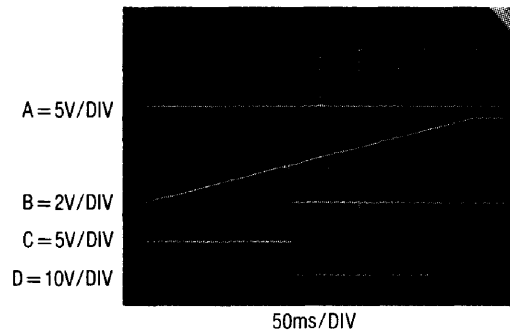

Figure 15. A–D Waveforms—Isolated Section

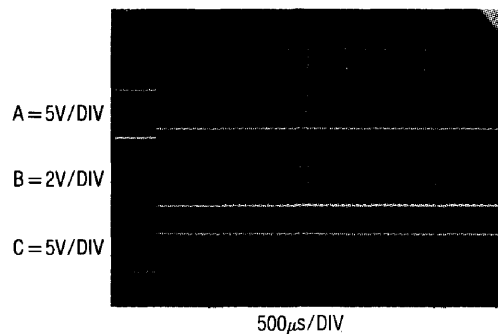

Figure 16. Detail of A–D Waveforms—Grounded Section

Linear Power Supplies—Past, Present, and Future

The amplitude of linear circuitry's power supplies has been determined by the available technology used for linear functions.

Probably the first standard linear supply was $\pm 300V$, used in analog computers. The operating characteristics of vacuum tubes necessitated high voltages. Additionally, because analog computers (from which operational amplifiers descended) were mathematical machines, bipolar supplies were desirable for computational purposes. With the arrival of solid state linear components in the early 1960's, new supply voltages were necessary and desirable. $\pm 15V$ was adapted because of transistor breakdown limits, as well as the availability of low voltage references (zener and avalanche diodes). Power and size advantages afforded by the new supply standard were also obviously attractive. It is significant that while the supply drop decreased available dynamic range of operation by over 20dB, the usable signal processing range did not decrease. This was due to the lower noise and drift of the solid state components.

The arrival of monolithic linear circuits in the late 1960's and subsequent design refinements expanded the available territory at the lower end of the signal processing range.

Currently available precision linear components and technology shifts are causing reevaluation of the power supply issue. In particular, several trends argue for linear functions to be able to operate from the low voltage digital rail. The increasing digital content of systems makes 5V compatible linear components attractive. Cost and space considerations in these systems often make separate linear supplies undesirable. This situation is not universal, and never will be, but is increasingly common.

A move to lower voltages for digital circuits, which must occur, underscores the need for low voltage, high performance linear ICs. Drops in digital supply value will be forced by increasing density requirements, which will lower IC breakdown limits.

Lower power consumption in systems goes along with supply voltage and density issues. Increasingly complex

systems are being put into smaller physical spaces, necessitating attention to dissipation. In many instances, portable operation is desirable, so circuitry must be directly compatible with battery potentials, as well as lower power. Linear components must not give up performance to function in this low voltage, digitally driven environment. Demands for precision remain high, and low voltage linear circuits, despite their narrowed dynamic operating range, must meet these requirements. This is not easy, considering that a 12 bit $\pm 15V$ system typically has a 2.5mV/LSB error budget. At 5V, this number shrinks to 1mV. To deal with this, design techniques developed for $\pm 15V$ components are being used in new, low voltage ICs and new approaches will also be employed.

Using Logic Supplies for Linear Functions

The fast clocking and transient high currents characteristic of digital systems make logic supplies an unfriendly place for linear components to operate. A key to achieving good results is considering power bus routing as an integral part of the signal processing chain. The figure shows that supply rail impedances will cause both DC and AC errors at various points in a system. This is true of any power distribution scheme, but is especially troublesome in digitally oriented systems, where fast current spiking and clock harmonics are present. Circuitry located at position "A" will see appreciable positive rail noise and ground potential will be corrupted by fast, relatively high currents returning through conductor impedances. Supply bypassing can reduce positive rail noise, but ground potential uncertainty can cause unacceptable errors. Locating linear circuits as shown in "B" reduces both positive and ground rail problems by eliminating the digitally derived currents. The linear devices lower operating currents allow lower errors due to supply distribution impedances. Appropriate bypassing techniques are also shown. LC filters can be substantially more effective than simple capacitors, especially in cases where it is not practical to route the positive rail directly from the supply. RC filtering forces voltage drop across the resistor, but is often acceptable due to the linear components low power requirements.

Application Note 11

In many cases it is not possible to arrange a "clean" supply for the linear components. In such circumstances it may be possible to synchronize noise sensitive linear circuit operations to occur between system clock pulses. This approach utilizes the synchronous nature of most digital systems and the fact that supply bus disturbances are often minimized between clock pulses.

Probably the most effective technique for dealing with digital supply noise is to galvanically isolate the linear circuits from the supply. The most obvious way to do this is provision of separate power supplies for the linear circuits, but this is often unacceptable. Instead, transformer and optical isolation circuit techniques allow logic rail driven, galvanically isolated circuits (see Figures 11, 12 and 14).

